

HEAT EXCHANGERS | aico 

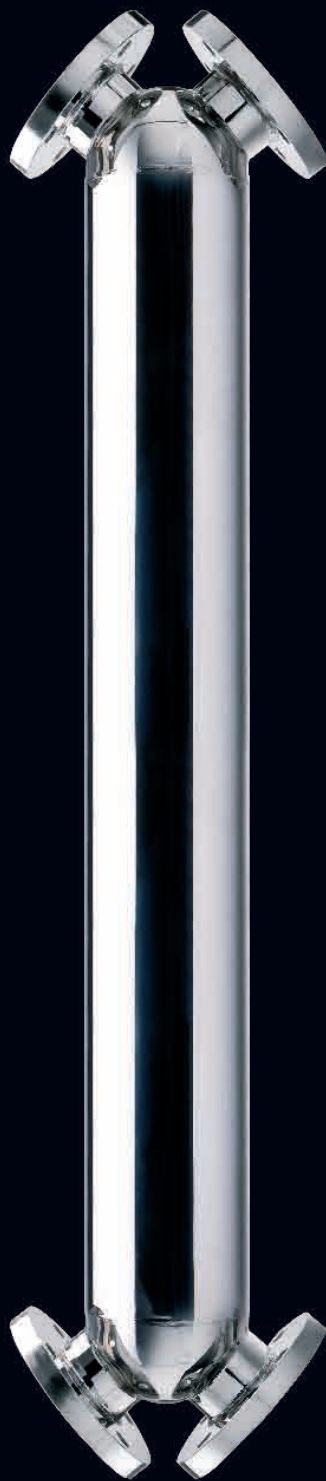

jad

jad

JAD heat exchangers are distinctive in every sense of the word. From the helically coiled tube bundles to the innovative angular connections, the JAD is a perfect balance of engineering craftsmanship and exceptional performance. Designed to deliver, whenever, wherever, they are required.

A product of tomorrow's technology.



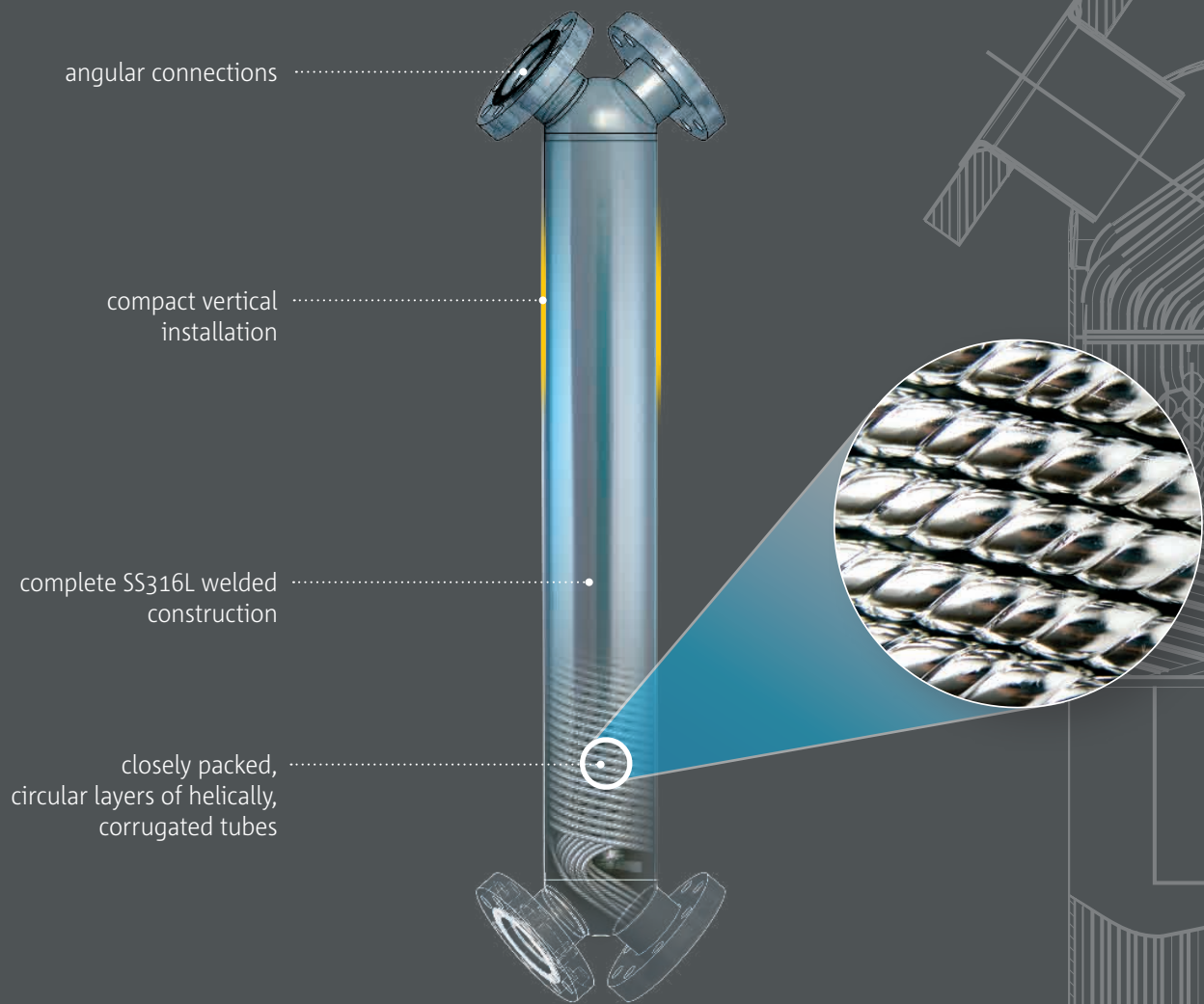

Typical Applications

- district energy heating
- hydronic heating
- steam-water systems (flooding heat exchangers)
- chilled water systems
- ground water systems
- refrigeration systems (ammonia absorption, freon)
- clean steam generation
- vapour condensers

JAD Typical Construction

- SS316L welded material of construction
- helically coiled tube bundles (corrugated or smooth)
- cascading connections
- vertical installation

Advantages

- large heat transfer surface area within a compact space results in a highly efficient and effective system
- complete SS316L welded construction ensures strength and durability of product
- in reboiler applications design allows superheating of the steam
- as a vapour condenser it sub-cools the condensate
- coiled tube bundle and cascading connection angles prevent debris build-up, creating a self-cleansing effect
- compact vertical design requires small installation footprint – ideal for applications with space constraints

JAD LINE

The JAD is unique in design, and diverse in capacity. Developed for flexibility, it can be an integral component of any sophisticated heat recovery system, while just as suitable for every day use.

Every component of this heat exchanger is engineered to optimize performance, resulting in a compact, highly efficient and effective system.

One of the most characteristic features of the JAD family is the closely packed, circular layers of helically, corrugated tubes that constitute the tube bundle. Each layer is positioned in the opposite direction to the surrounding layer, resulting in an overall criss-cross pattern. The effect is a high heat transfer surface area within a compact space. The tube orientation fosters turbulent flow and creates more uniform heating of the fluids, thus increasing the overall heat transfer coefficient.

Additionally, the inherent spring-like characteristics of the coiled tube bundle enable these heat exchangers to withstand high temperature differentials between the two mediums, variations in steam pressures, and possible steam hammers and shocks in the system.

The JAD angular connections accommodate smooth, gradual flow entrances and exits from the unit, reducing any sharp corners that can result in flow separation and where dirt buildup can occur.

The vertical configuration has the intrinsic advantage of being used as a condenser or evaporator for supporting changes of fluid phases within the unit (e.g. steam to liquid). The small footprint results in less installation space requirements and low installation costs. It is ideal for applications with space constraints.

The strength and durability of JAD heat exchangers are due to their complete welded, stainless steel 316L material of construction. This allows for high pressure and temperature ratings on standard products, and ensures that the products are suited for the most demanding of applications. After fabrication, the heat exchangers are additionally passivated and electropolished to enhance the corrosion resistance of the material.

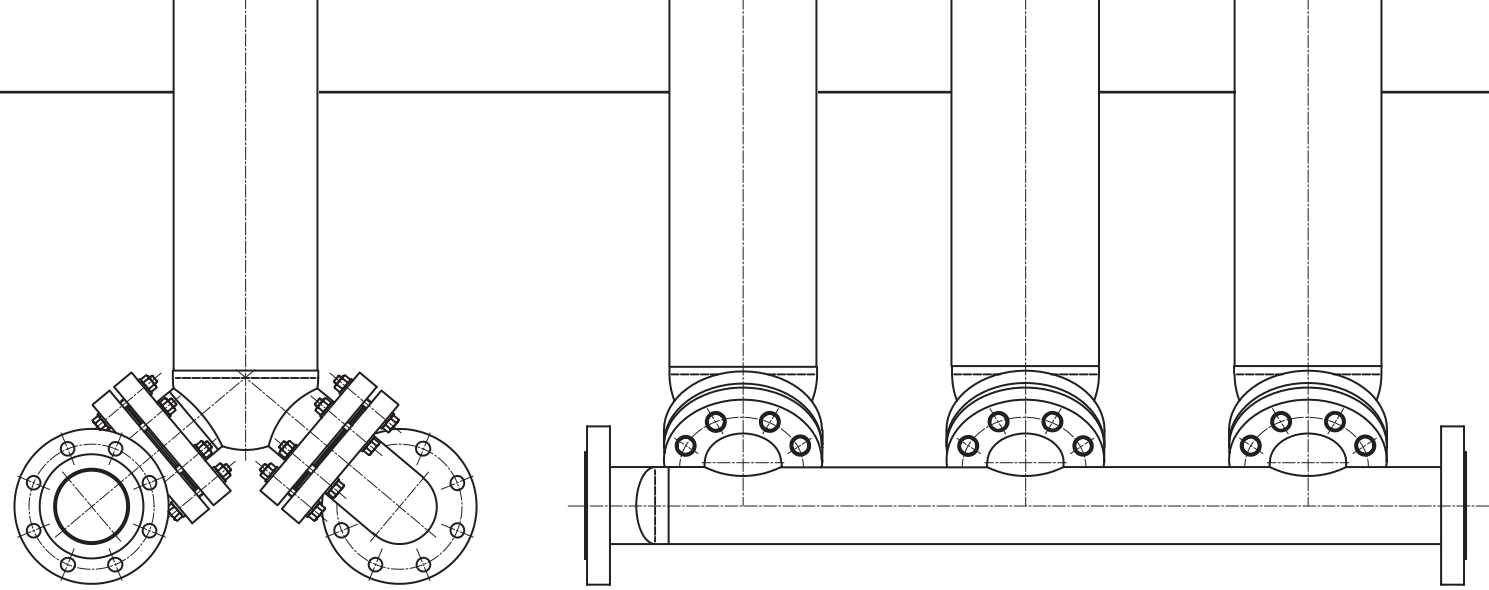

Steam

Flooded Heat Exchanger

For steam applications, contrary to conventional designs, the unique JAD helically corrugated tube bundles and its vertical structure enable the heat exchanger to not only condense the steam, but also to sub-cool the condensate to within degrees of the incoming cold water, recovering the maximum amount of excess heat available. The bottom of the heat exchanger can be flooded to various degrees with condensate, enabling the operator to have smoother and better control of the performance of the overall system.

Clean Steam Production

The vertical JAD design is often used in the generation of clean steam. Considered a refined 'thermosiphon reboiler', the partially flooded exchanger has the ability to superheat the steam, facilitating better control of the steam output, and allowing the transport of dry steam to other parts of the system. Additionally, its compactness is more desirable than standard submerged kettletype reboilers, which has larger footprint requirements.

Jadfamily

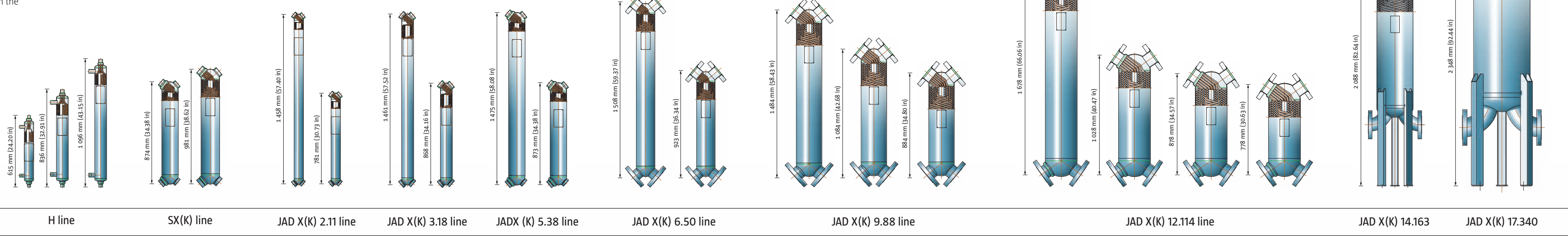

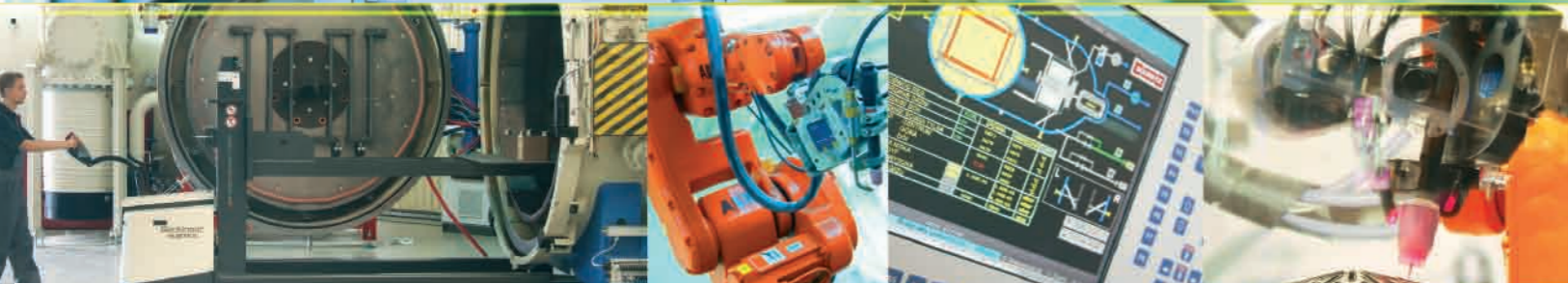
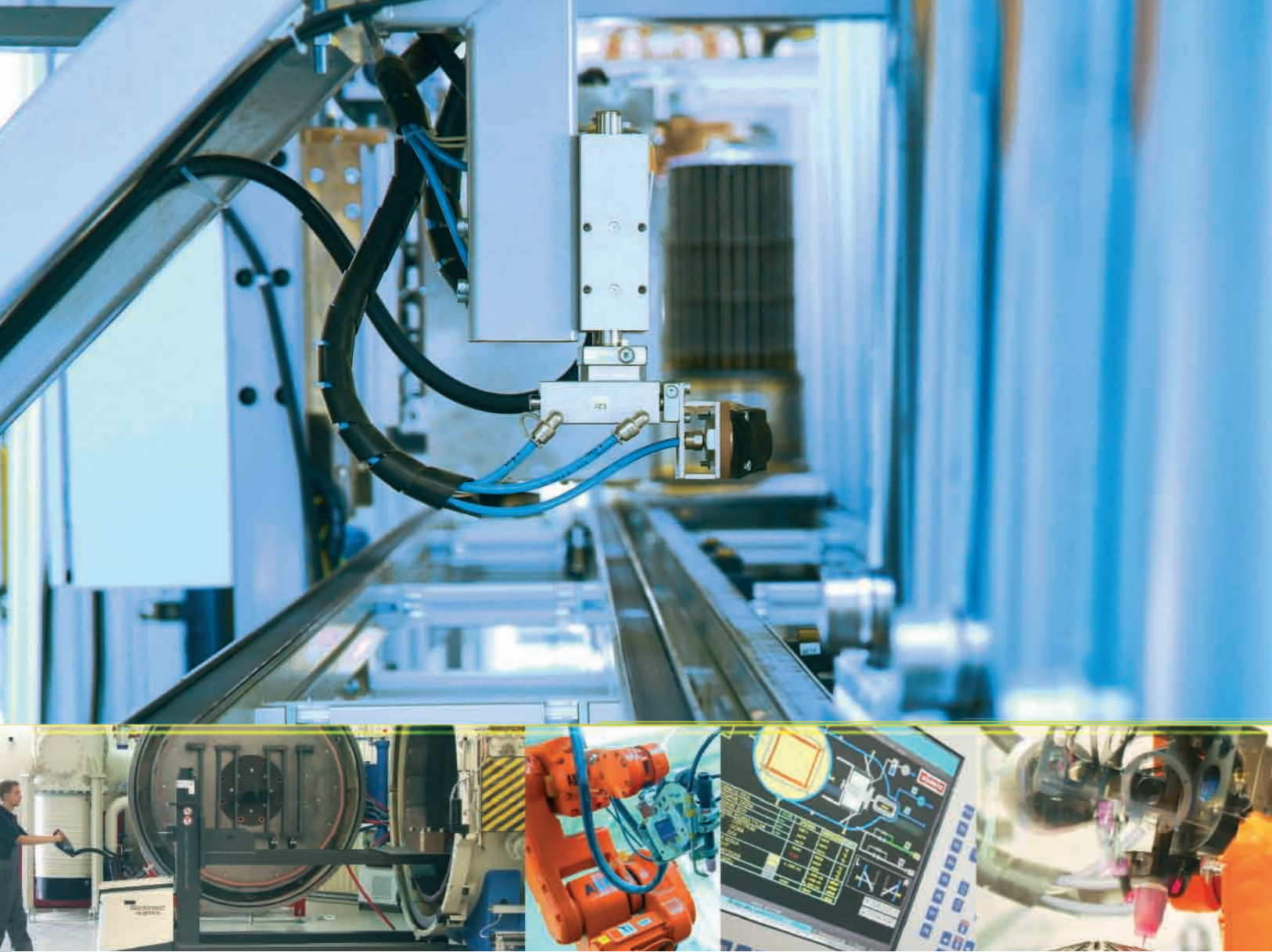

AIC Organization

AIC is a manufacturer of heat exchangers and custom-designed heat transfer, and heat recovery, products.

We value engineering excellence. Our strengths lie in the high quality and fine craftsmanship of our products, the engineering expertise of our team, and our quest to continuously develop technologically new and exciting products. AIC's diverse product offerings are installed worldwide.

Our state-of-the-art facilities utilize the most leading edge processes, advanced automated and robotic systems, and well sourced materials for the most stringent of applications. With our own tube mills, ovens, and CNC machines, we can design, manufacture, and control every part of our process.

Our stringent quality management system ensures that we continue our dominance in providing top quality products that clients have come to associate with the AIC brand.



Technical Product Specifications

TYPE	Heat Transfer Area		Height		Diameter		Connections
	m ²	sq ft	mm	in	mm	in	in
HELICALLY CORRUGATED TUBES							
H-0K	0.29	3.1	615	24.20	80	3.15	3/4
H-1K	0.76	8.2	836	32.91	102	4.00	1
H-2K	1.32	14.2	1 096	43.15	102	4.00	1
JAD XK 2.11	1.20	12.9	1 458	57.40	80	3.15	1 1/2
JAD XK 2.11.08.68	0.63	6.8	781	30.73	80	3.15	1 1/2
JAD XK 3.18	2.00	21.5	1 461	57.52	102	4.00	2
JAD XK 3.18.08.75	1.20	12.9	868	34.16	102	4.00	2
S-0XK	2.30	24.8	874	34.38	140	5.50	2
S-1XK	3.14	33.8	981	38.62	159	6.26	2 1/2
JAD XK 5.38	4.00	43.1	1 475	58.08	140	5.50	2
JAD XK 5.38.08.71	2.30	24.8	873	34.38	140	5.50	2
JAD XK 6.50	5.70	61.4	1 508	59.37	159	6.26	3
JAD XK 6.50.08.72	3.14	33.8	923	36.34	159	6.26	3
JAD XK 9.88	10.70	115.2	1 484	58.43	219	8.63	4
JAD XK 9.88.08.85	6.20	66.7	1 084	42.68	219	8.63	4
JAD XK 9.88.08.65	4.97	53.5	884	34.80	219	8.63	4
JAD XK 12.114	18.40	198.1	1 678	66.06	273	10.75	4
JAD XK 12.114.08.75	8.78	94.5	1 028	40.47	273	10.75	4
JAD XK 12.114.08.60	6.46	69.5	878	34.57	273	10.75	4
JAD XK 12.114.08.50	6.25	67.3	778	30.63	273	10.75	4
JAD XK 14.163.08.120	25.00	269.1	2 088	82.64	324	12.75	4
JAD XK 17.340.08.120	60.80	654.4	2 348	92.44	508	20.00	6

SMOOTH TUBES							
JAD X 2.11	1.20	12.9	1 458	57.40	80	3.15	1 1/2
JAD X 3.18	2.00	21.5	1 461	57.52	102	4.00	2
JAD X 5.38	4.00	43.1	1 478	58.19	140	5.50	2 1/2
JAD X 6.50	5.70	61.4	1 508	59.37	159	6.26	3
JAD X 9.88	10.70	115.2	1 484	58.43	219	8.63	4
JAD X 12.114	18.40	198.1	1 678	66.06	273	10.75	4

THREADED CONNECTIONS AVAILABLE UP TO 2-1/2 INCH
 FLANGE CONNECTIONS AVAILABLE FROM 2 INCH AND LARGER - COMPATIBLE TO PN 10/ PN 16 OR ANSI 150LB / 300LB

MATERIAL OF CONSTRUCTION		
	standard	optional
SHELL	STAINLESS STEEL 316L	—
TUBES	STAINLESS STEEL 316L	—
NOZZLE	STAINLESS STEEL 316L	—
FLANGES	STAINLESS STEEL 316L LINED	SOLID STAINLESS STEEL

STANDARD DESIGN PARAMETERS		
	TUBES	SHELL
TEMPERATURE	217°C (422°F)	217°C (422°F)
PRESSURE	21 bar (300 PSI)	21 bar (300 PSI)

OPTIONAL RATINGS AVAILABLE UPON REQUEST



Performance

The JAD design has fundamental advantages over conventional straight or u-tube heat exchangers. Originally designed and manufactured specifically for the district energy market, it has since transcended into the mainstream heat recovery market, surpassing competitors in efficiency and performance capabilities.

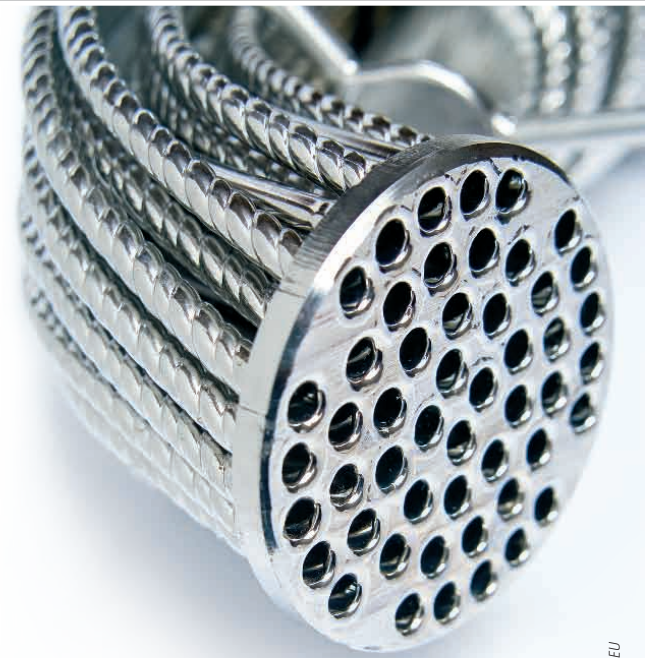

We are certified by renowned international inspection authorities. Our quality process and management systems fulfill the requirements of ISO 9001 Quality Management System. AIC heat exchangers are designed, tested and manufactured in accordance with ASME (Section IV and VIII) and PED (97/23/UE) regulations.



AIC s.a.
ul. Rdestowa 41
81-577 Gdynia, POLAND
T. +4858 785 61 64
F. +4858 785 61 60
E. info@myaic.com

Authorized Representative